

# PMC Panel Mount Power Supply

## 12V 600W 1 Phase / PMC-12V600W1BA



# PMC

### Highlights & Features

- Universal AC input range
- Built-in active PFC and high efficiency up to 89% @ 230Vac
- Power Boost of 200% for 3 seconds and 150% for 5 seconds
- SEMI F47 compliance at 120Vac
- Meet Surge Immunity IEC 61000-4-5, Level 4 (CM: 4kV, DM: 2kV)
- Built-in fan speed control and fan lock protection
- Wide operating temperature range -20°C to 70°C
- Overvoltage / Overcurrent / Over Temperature / Short Circuit Protections



### Safety Standards



CB Certified for worldwide use

**Model Number:** PMC-12V600W1BA  
**Unit Weight:** 1.51 kg (3.33 lb)  
**Dimensions (L x W x D):** 215 x 120 x 61 mm  
 (8.46 x 4.72 x 2.40 inch)

### General Description

The PMC-12V600W1BA has a power rating of 600W with 12V output voltage. The product features Power Boost of 200% (peak load 12V 100A) for 3 seconds and built-in fan speed control with fan lock protection. The PMC-12V600W1BA accepts the full universal AC input range and have been approved for major safety standards like IEC/EN/UL 62368-1 approval that will replace IEC 60950-1 for ITE which expires on December 20, 2020. EMI according to EN 55011 (Industrial, scientific and medical (ISM) radio-frequency equipment) and EMS according to EN 61000-6-2 (Immunity for industrial environments).

### Model Information

PMC Panel Mount Power Supply

Model Number	Input Voltage Range	Rated Output Voltage	Rated Output Current
PMC-12V600W1BA	85-264Vac (120-375Vdc)	12Vdc	50.0A

### Model Numbering

PM	C –	12V	600W	1	B	A
Panel Mount	Product Type C – Enclosed	Output Voltage	Output Power	Single Phase	With PFC	Front Face connector

# PMC Panel Mount Power Supply

## 12V 600W 1 Phase / PMC-12V600W1BA

### Specifications

#### Input Ratings / Characteristics

Nominal Input Voltage	100-240Vac		
Input Voltage Range*	85-264Vac		
Nominal Input Frequency	50-60Hz		
Input Frequency Range	47-63Hz		
DC Input Voltage Range**	120-375Vdc		
Input Current	< 6.50A @ 115Vac, < 3.20A @ 230Vac		
Efficiency at 100% Load	> 85.5% @ 115Vac, > 89.0% @ 230Vac		
Max Power Dissipation	No Load	< 7W @ 115Vac, < 8W @ 230Vac	
	100% Load	< 105W @ 115Vac, < 75W @ 230Vac	
Max Inrush Current (Cold Start)	< 10A @ 115Vac & < 20A @ 230Vac		
Power Factor	> 0.98 @ 115Vac, > 0.95 @ 230Vac		
Leakage Current	IEC/EN/UL 60950-1	< 1.5mA / 1.5mA @ 264Vac	TN/TT system / IT system
	IEC/EN/UL 62368-1	< 3.0mA / 4.0mA @ 264Vac	TN/TT system / IT system

\*For power de-rating at 85-115Vac, see power de-rating on page 3.

\*\*Fulfills test conditions for DC input. Safety approval for DC input can be obtained upon request.

#### Output Ratings / Characteristics\*\*\*

Nominal Output Voltage	12Vdc	
Factory Set Point Tolerance	12Vdc $\pm$ 1%	
Output Voltage Adjustment Range	10.8-13.2Vdc	
Output Current	0-50A	Continuously operating at 10.8V / 12V
	0-45.45A	Continuously operating at 13.2V
Output Power	540W	Continuously operating at 10.8V
	600W	Continuously operating at 12V / 13.2V
Power Boost	75A for 5 seconds	At 12V output
	100A for 3 seconds	At 12V output
Line Regulation	< 48mV (@ 115-264Vac input, 100% load)	
Load Regulation	< 100mV (@ 115-264Vac input, 0-100% load)	
PARD**** (20MHz)	< 240mVpp	
Rise Time	< 50ms @ 115Vac & 230Vac (100% load)	
Start-up Time	< 500ms @ 115Vac & 230Vac (100% load)	
Hold-up Time	> 20ms @ 115Vac & 230Vac (100% load)	
Dynamic Response (Overshoot & Undershoot O/P Voltage)	$\pm$ 5% @ 115-264Vac input, 10-100% (Slew Rate: 0.1A/ $\mu$ S, 50% duty cycle @ 5Hz to 1kHz)	
Start-up with Capacitive Loads	10,000 $\mu$ F Max	

\*\*\*For power de-rating from 50°C to 70°C, see power de-rating on page 3.

\*\*\*\*PARD is measured with an AC coupling mode, 5cm wires, and in parallel with 0.1 $\mu$ F ceramic capacitor & 47 $\mu$ F electrolytic capacitor.

# PMC Panel Mount Power Supply

## 12V 600W 1 Phase / PMC-12V600W1BA

### Mechanical

Case Chassis / Cover		SECC
Dimensions (L x W x D)		215 x 120 x 61 mm (8.46 x 4.72 x 2.40 inch)
Unit Weight		1.51 kg (3.33 lb)
LED Indicator	Green LED	DC OK
Cooling System		Forced Cooling (Built-in Fan)
Terminal	Input	M3.5 x 3 Pins (Rated 300V/20A)
	Output	M6 x 2 Pins (Rated 600V/50A)
Wire	Input	AWG 14-12
	Output	AWG 6-4
Noise (1 Meter from power supply)		Sound Pressure Level (SPL) < 52dBA

### Environment

Surrounding Air Temperature	Operating	-20°C to +70°C (Cold start -40°C)
	Storage	-40°C to +75°C
Power De-rating	Temperature	> 50°C de-rate power by 2.5% / °C
	Input Voltage	< 115Vac de-rate power by 0.67% / 1V < 162Vac de-rate power by 0.48% / 1V
Operating Humidity		5 to 95% RH (Non-Condensing)
Operating Altitude		0 to 3,000 Meters (9,840 ft.)
Shock Test	Non-Operating	IEC 60068-2-27, 30G (300m/S <sup>2</sup> ) for a duration of 18ms, 1 times per direction, 2 times in total
Vibration	Non-Operating	IEC 60068-2-6, 10Hz to 150Hz @ 50m/S <sup>2</sup> (5G peak); displacement of 0.35mm; 20 min per axis for all X, Y, Z direction
Bump	Operating	IEC 60068-2-29, 10G (100m/S <sup>2</sup> ) for a duration of 11ms, 1000 times per direction, 6000 times in total direction
Over Voltage Category		II
Pollution Degree		2

### Protections

Overvoltage	< 17.6V, SELV Output, Latch Mode
Overload / Overcurrent	> 150% of rated load current, Hiccup Mode, Non-Latching (Auto-Recovery)
Over Temperature	< 80°C Surrounding Air Temperature @ 100% load, Latch Mode
Short Circuit	Hiccup Mode, Non-Latching (Auto-Recovery when the fault is removed)
Fan Lock	Latch Mode
Internal Fuse at L pin	F 12.5AH
Protection Against Shock	Class I with PE* connection

\*PE: Primary Earth

# PMC Panel Mount Power Supply

## 12V 600W 1 Phase / PMC-12V600W1BA



### Reliability Data

MTBF	> 700,000 hrs. as per Telcordia SR-332 I/P: 115Vac & 230Vac, O/P: 100% load, Ta: 25°C
Expected Cap Life Time	10 years (115Vac & 230Vac, 50% load @ 40°C)

### Safety Standards / Directives

Safety Entry Low Voltage		SELV (EN 60950-1)
Electrical Safety	SIQ Bauart	EN 60950-1, EN 62368-1
	UL/cUL recognized	UL 60950-1 and CSA C22.2 No. 60950-1 (File No. E191395), UL 62368-1 and CSA C22.2 No. 62368-1 (File No. E191395)
	CB scheme	IEC 60950-1, IEC 62368-1
CE		In conformance with EMC Directive 2014/30/EU and Low Voltage Directive 2014/35/EU
Material and Parts		RoHS Directive 2011/65/EU Compliant
Galvanic Isolation	Input to Output	3.0KVac
	Input to Ground	2.0KVac
	Output to Ground	0.5KVac

# PMC Panel Mount Power Supply

## 12V 600W 1 Phase / PMC-12V600W1BA



### EMC

Emissions (CE & RE)	CISPR 32, EN 55032, CISPR 11, EN 55011, FCC Title 47, VCCI <sup>1)</sup> : Class B		
Immunity	EN 55024, EN 61000-6-2		
Electrostatic Discharge	IEC 61000-4-2	Level 4 Criteria A <sup>2)</sup> Air Discharge: 15kV Contact Discharge: 8kV	
Radiated Field	IEC 61000-4-3	Level 3 Criteria A <sup>2)</sup> 80MHz-1GHz, 10V/M with 1kHz tone / 80% modulation 1.4GHz-2GHz, 3V/M with 1kHz tone / 80% modulation 2GHz-2.7GHz, 1V/M with 1kHz tone / 80% modulation	
Electrical Fast Transient / Burst	IEC 61000-4-4	Level 4 Criteria A <sup>2)</sup> 4kV	
Surge	IEC 61000-4-5	Level 4 Criteria A <sup>2)</sup> Common Mode <sup>3)</sup> : 4kV Differential Mode <sup>4)</sup> : 2kV	
Conducted	IEC 61000-4-6	Level 3 Criteria A <sup>2)</sup> 150kHz-80MHz, 10Vrms	
Power Frequency Magnetic Fields	IEC 61000-4-8	Criteria A <sup>2)</sup> 30A/Meter	
Voltage Dips and Interruptions	IEC 61000-4-11	0% of 100Vac, 20ms 40% of 100Vac, 200ms 70% of 100Vac, 500ms 0% of 100Vac, 5000ms 0% of 240Vac, 20ms 40% of 240Vac, 200ms 70% of 240Vac, 500ms 0% of 240Vac, 5000ms	Criteria A <sup>2)</sup> Criteria B <sup>3)</sup> Criteria B <sup>3)</sup> Criteria B <sup>3)</sup> Criteria A <sup>2)</sup> Criteria A <sup>2)</sup> Criteria A <sup>2)</sup> Criteria B <sup>3)</sup>
Low Energy Pulse Test (Ring Wave)	IEC 61000-4-12	Level 3 Criteria A <sup>2)</sup> Common Mode <sup>4)</sup> : 2kV Differential Mode <sup>5)</sup> : 1kV	
Harmonic Current Emission	IEC/EN 61000-3-2, Class A		
Voltage Fluctuation and Flicker	IEC/EN 61000-3-3		
Voltage Sag Immunity SEMI F47 – 0706	80% of 120Vac 70% of 120Vac 50% of 120Vac 80% of 200Vac 70% of 200Vac 50% of 200Vac	96Vac, 1000ms 84Vac, 500ms 60Vac, 200ms 160Vac, 1000ms 140Vac, 500ms 100Vac, 200ms	Criteria A <sup>2)</sup> Criteria A <sup>2)</sup> Criteria B <sup>3)</sup> Criteria A <sup>2)</sup> Criteria A <sup>2)</sup> Criteria A <sup>2)</sup>

1) Fulfills tested conditions  
 2) Criteria A: Normal performance within the specification limits  
 3) Criteria B: Temporary degradation or loss of function which is self-recoverable  
 4) Asymmetrical: Common mode (Line to earth)  
 5) Symmetrical: Differential mode (Line to line)

# PMC Panel Mount Power Supply

## 12V 600W 1 Phase / PMC-12V600W1BA

### Block Diagram

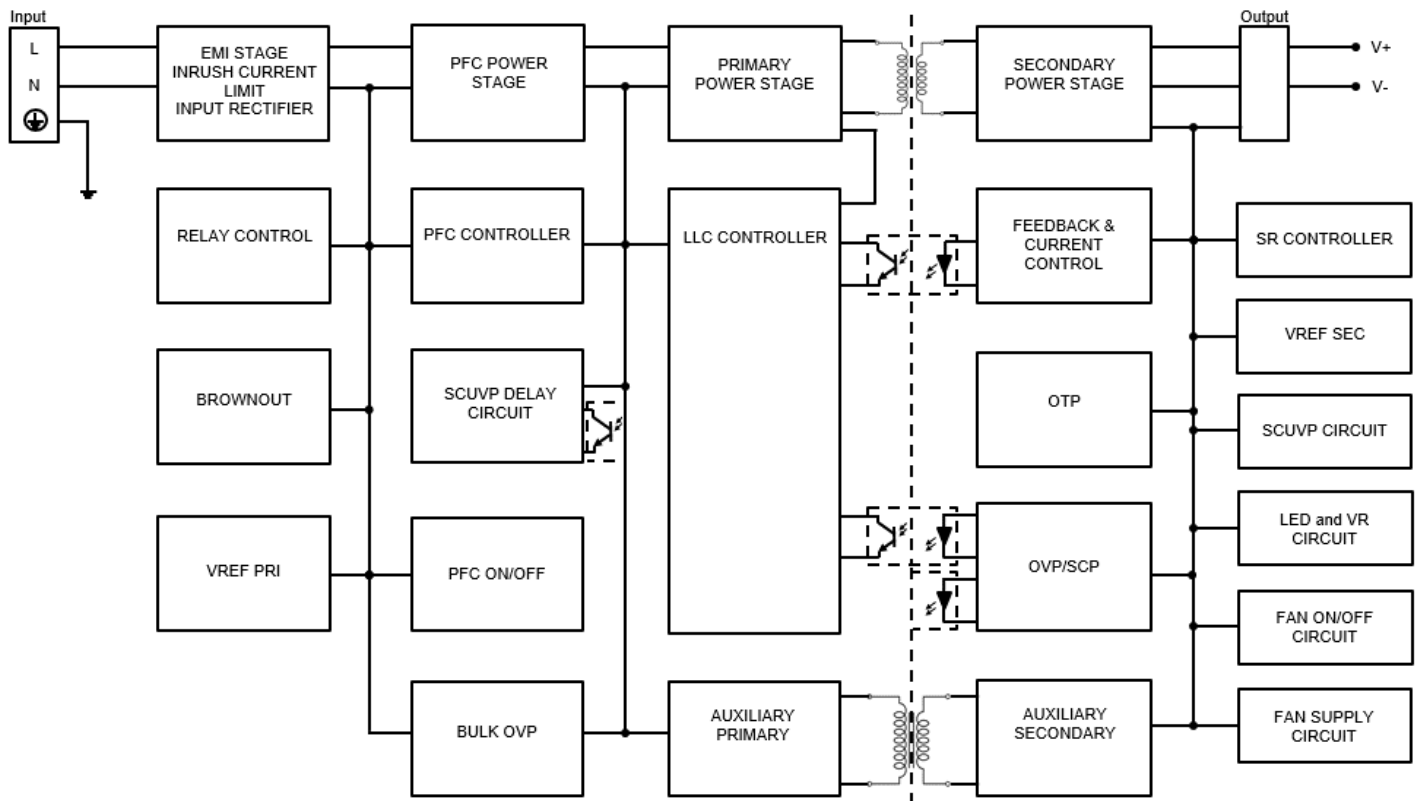

### Device Description

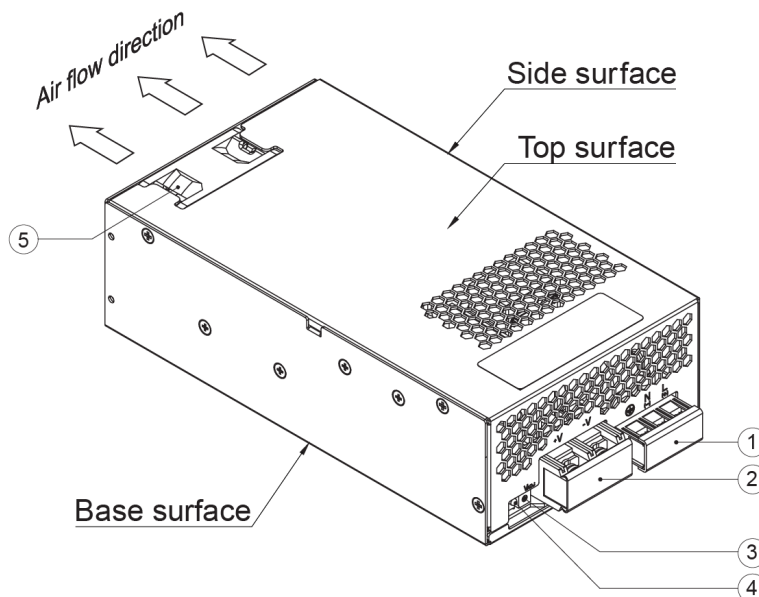

- 1) Input terminal block connector
- 2) Output terminal block connector
- 3) DC voltage adjustment potentiometer
- 4) DC OK control LED (Green)
- 5) DC Fan

# PMC Panel Mount Power Supply

## 12V 600W 1 Phase / PMC-12V600W1BA

### Dimensions

L x W x D: 215 x 120 x 61 mm (8.46 x 4.72 x 2.40 inch)

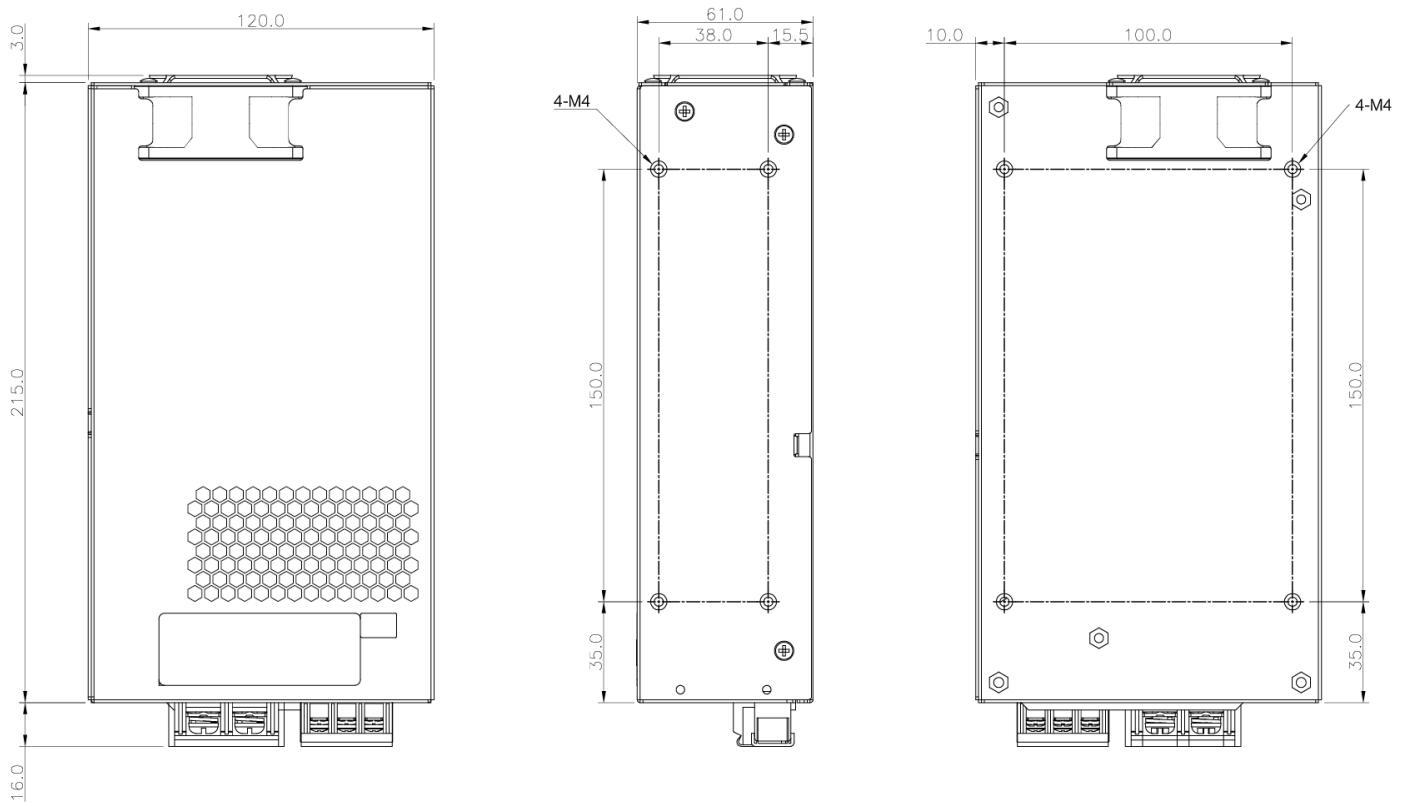

### Engineering Data

#### Output Load De-rating VS Surrounding Air Temperature

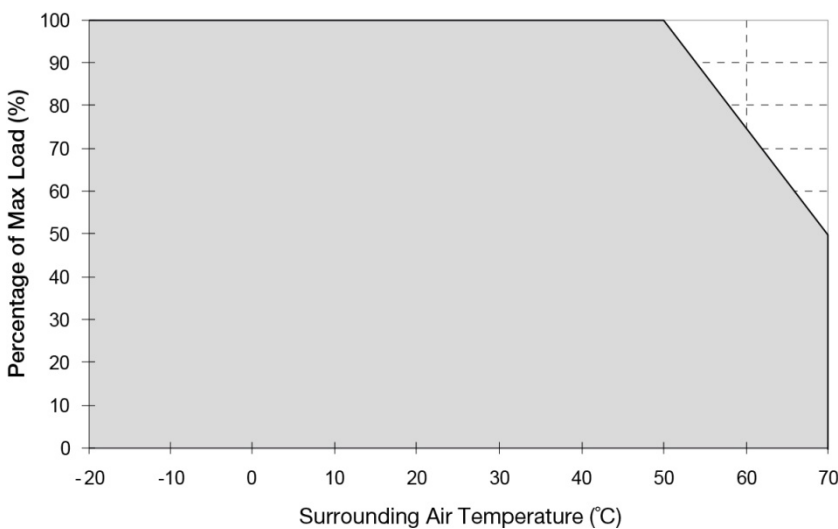

**Fig. 1 De-rating for Vertical and Horizontal Mounting Orientation**  
 > 50°C de-rate power by 2.5% / °C

#### Note

1. Power supply components may degrade, or be damaged, when the power supply is continuously used outside the shaded region, refer to the graph shown in Fig. 1.
2. If the output capacity is not reduced when the surrounding air temperature exceeds its specification as defined on Page 3 under "Environment", the device may run into Over Temperature Protection. When activated, the output voltage will go into latch mode until the mains is reapplied and the surrounding air temperature drops to its normal operating temperature.
3. In order for the device to function in the manner intended, it is also necessary to keep a safety distance as recommended in the safety instructions while the device is in operation.
4. Depending on the surrounding air temperature and output load delivered by the power supply, the device can be very hot!
5. If the device has to be mounted in any other orientation, please contact [info@deltapsu.com](mailto:info@deltapsu.com) for more details.

# PMC Panel Mount Power Supply

## 12V 600W 1 Phase / PMC-12V600W1BA

### Output Load De-rating VS Input Voltage

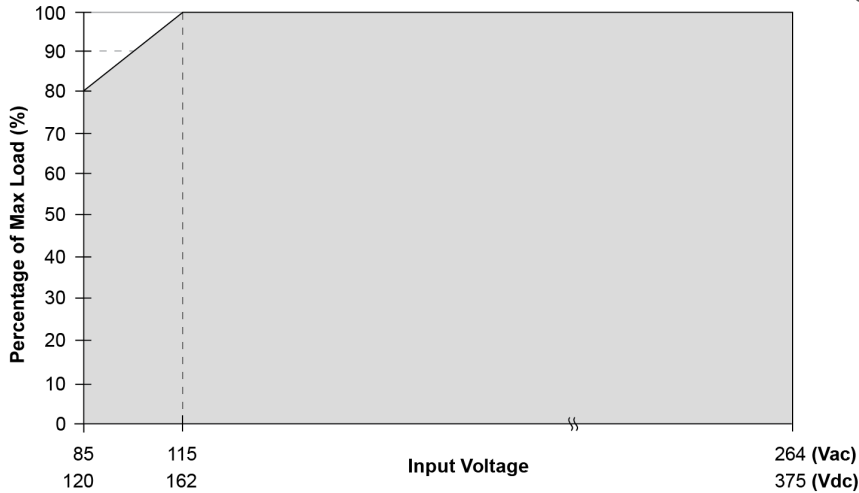

■ Output de-rating is required at 85Vac to 115Vac or 120Vdc to 162Vdc.

### Assembly & Installation

- Ⓐ Mounting holes for power supply assembly onto the mounting surface.  
The power supply shall be mounted on minimum 4 mounting holes using M4 screw minimum 5mm (0.20 inch) length.
- Ⓑ Input / Output Connector
- Ⓒ This surface belongs to customer's end system or panel where the power supply is mounted.

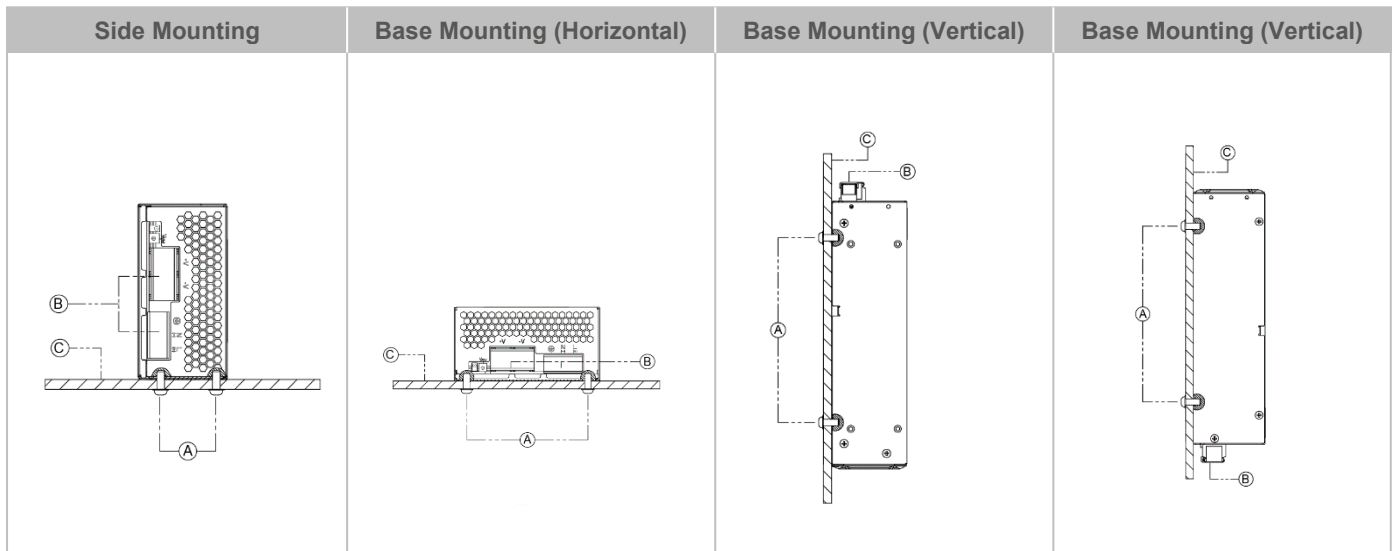

Fig. 2 Mounting Orientation

- Please refer the table below for the recommended AWG wire size and torque.

	AWG	Torque (Kgf.cm)
Input connector <sup>(1)</sup>	14-12	11.98
Output connector <sup>(2)</sup>	6-4	32.00

1) Use flexible cables. The insulation stripping length should not exceed 0.275" or 7mm.  
2) Use flexible cables with ring or fork terminals.



# PMC Panel Mount Power Supply

## 12V 600W 1 Phase / PMC-12V600W1BA

### Installation of Mounting Accessories

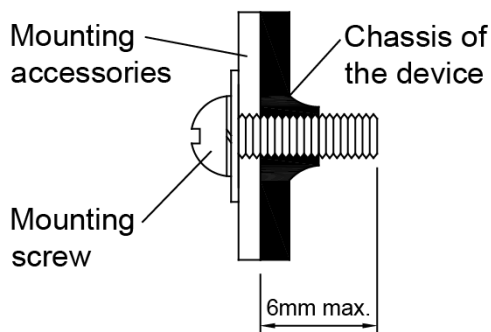

- Only use M4 screw  $\leq 6\text{mm}$  (0.24 inch) through the base mounting holes. This is to keep a safe distance between the screw and internal components.
- Recommended mounting tightening torque: 4~8 Kgf.cm (3.47~6.94 lbf.in)

### Safety Instructions

- To ensure sufficient convection cooling, always maintain a safety distance of  $\geq 50\text{mm}$  (1.97 inch) from all ventilated surfaces while the device is in operation.
- The device is not recommended to be placed on low thermal conductive surface, for example, plastics.
- Note that the enclosure of the device can become very hot depending on the ambient temperature and load of the power supply. Do not touch the device while it is in operation or immediately after power is turned OFF. Risk of burning!
- Do not touch the terminals while power is being supplied. Risk of electric shock.
- Prevent any foreign metal, particles or conductors from entering the device through the openings during installation. It may cause: Electric shock; Safety Hazard; Fire; Product failure
- Warning: When connecting the device, secure Earth connection before connecting L and N. When disconnecting the device, remove L and N connections before removing the Earth connection.

# PMC Panel Mount Power Supply

## 12V 600W 1 Phase / PMC-12V600W1BA



### Functions

- Graph illustrating the Start-up Time, Rise Time, and Hold-up Time

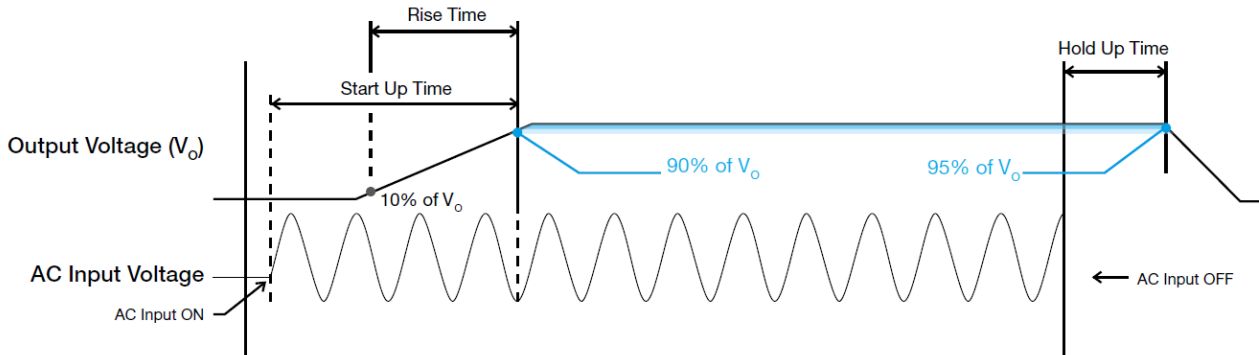

### Start-up Time

The time required for the output voltage to reach 90% of its final steady state set value, after the input voltage is applied.

### Rise Time

The time required for the output voltage to change from 10% to 90% of its final steady state set value.

### Hold-up Time

Time between the collapse of the AC input voltage, and the output falling to 95% of its steady state set value.

### Inrush Current

Inrush current is the peak, instantaneous, input current measured and, occurs when the input voltage is first applied. For AC input voltages, the maximum peak value of inrush current will occur during the first half cycle of the applied AC voltage. This peak value decreases exponentially during subsequent cycles of AC voltage.

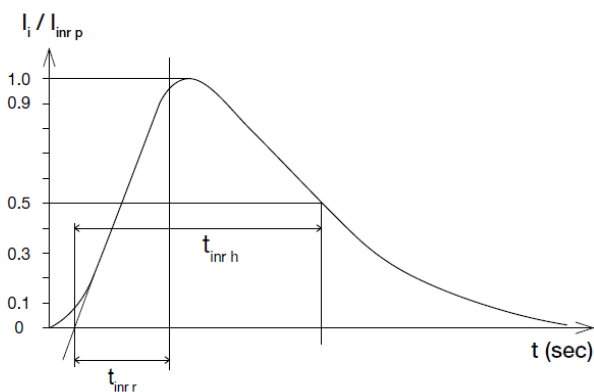

### Dynamic Response

The power supply output voltage will remain within  $\pm 5\%$  of its steady state value, when subjected to a dynamic load from 10% to 100% of its rated current.

- 50% duty cycle / 5Hz to 1kHz

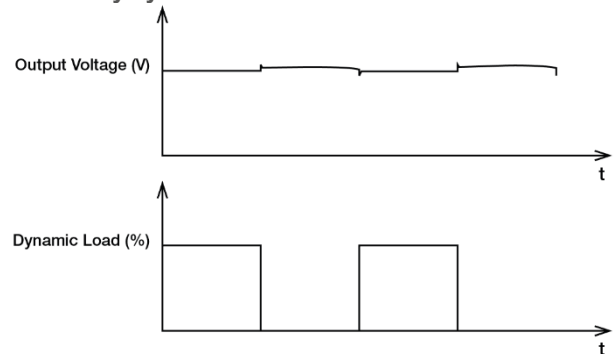

# PMC Panel Mount Power Supply

## 12V 600W 1 Phase / PMC-12V600W1BA

### Power Boost

Power Boost is the reserve power available constantly that allows reliable startup to support sudden and short spike of loads with high inrush current typically during turn on to remove the need of more expensive higher rated power supply unit. After the output has reached its steady state set value, the power supply can support surge loads with a higher short-term power demand up to 200% of maximum rated load ( $I_{O\ Max}$ ), for a maximum duration of 3 seconds. The Power Boost is also available to repeatedly basis with according to the condition of an average (R.M.S) output power shall not exceed continuous operating condition or refer to duty cycle calculation below.

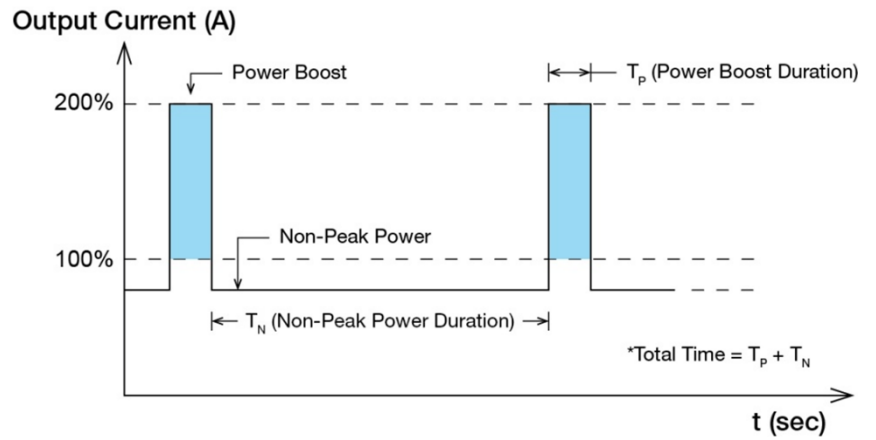

Fig. 3 Duty Cycle Calculation

$$Duty\ cycle\ (\%) = \frac{T_p}{Total\ Time}$$

$$Average\ Output\ Power\ (P_{Avg}) = \frac{(Power\ Boost \times T_p) + (Non-Peak\ Power \times T_n)}{Total\ Time}$$

OR

$$Non-Peak\ Power = \frac{(P_{Avg} \times Total\ Time) - (Power\ Boost \times T_p)}{T_n}$$

### ■ An example of Power Boost and Average Output Power

Power Boost	Peak Power (W <sub>P</sub> )	Power Boost Duration (T <sub>P</sub> )	Duty Cycle	Non-Peak Power (W <sub>N</sub> )	Non-Peak Power Duration (T <sub>N</sub> )	Total Time (T)
200%	1200	3 sec	10%	533	27 sec	30 sec
200%	1200	3 sec	35%	279	5.6 sec	8.6 sec
180%	1080	10 sec	20%	480	40 sec	50 sec
180%	1080	10 sec	35%	340	18.5 sec	28.5 sec
150%	900	15 sec	30%	471	35 sec	50 sec
150%	900	15 sec	35%	438	28 sec	43 sec
124%	744	20 sec	40%	504	30 sec	50 sec

It is not recommended to prolong the duration of Power Boost to be longer than the specified duty cycle calculation, this may cause damage to the PSU.

# PMC Panel Mount Power Supply

## 12V 600W 1 Phase / PMC-12V600W1BA



### Overload & Overcurrent Protections (Auto-Recovery)

The power supply's Overload (OLP) and Overcurrent (OCP) Protections will be activated when output current ( $I_o$ ) exceeds its specification as defined on Page 3 under "Protections". In such occurrence, the output voltage ( $V_o$ ) will start to droop and once the power supply has reached its maximum power limit, the protection is activated and the power supply will go into "Hiccup mode" (Auto-Recovery). The power supply will recover once the fault condition of the OLP and OCP is removed and  $I_o$  is back within the specifications.

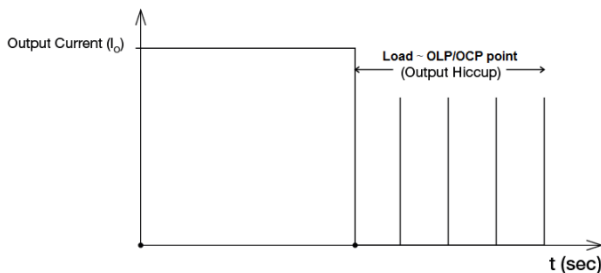

It is not recommended to prolong the duration of  $I_o$  when it is less than OLP/OCP point, but greater than 100%, since it may cause damage to the PSU.

### Short Circuit Protection (Auto-Recovery)

The power supply's output OLP/OCP function also provides protection against short circuits. When a short circuit is applied, the output current will operate in "Hiccup mode", as shown in the illustration in the OLP/OCP section on this page. The power supply will return to normal operation after the short circuit is removed.

### External Input Protection Device

The unit is protected with internal fuse (not replaceable) at L pin and it has been tested and approved on 20A (UL) and 16A (IEC) branch circuits without additional protection device. An external protection device is only required if the supplying branch has an ampacity greater than above. Thus, if an external protective device is necessary, or, utilized, please refer a minimum value of 10A B- or 6A C- characteristic breaker should be used.

### Overvoltage Protection (Latch Mode)

The power supply's overvoltage circuit will be activated when its internal feedback circuit fails. The output voltage shall not exceed its specifications defined on Page 3 under "Protections". Power supply will latch, and require removal/re-application of AC voltage in order to restart.

**The power supply should be latch, and require removal/re-application of input AC voltage in order to restart.**

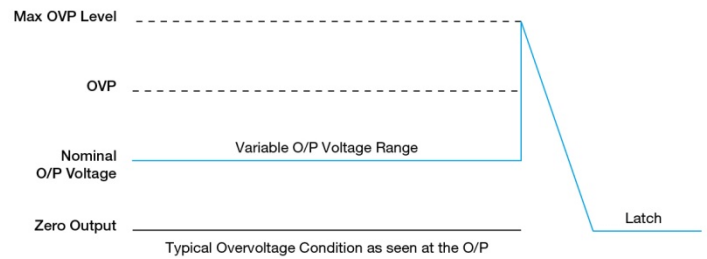

### Over Temperature Protection (Latch Mode)

As described in load de-rating section, the power supply also has Over Temperature Protection (OTP). In the event of a higher operating temperature at 100% load, the power supply will run into OTP when the operating temperature is beyond what is recommended in the de-rating graph. When activated, the output voltage will go into latch mode until the surrounding temperature drops to its normal operating temperature or the load is reduced as recommended in the de-rating graph. Removal/re-application of input AC voltage will then be required in order to restart.

# PMC Panel Mount Power Supply

## 12V 600W 1 Phase / PMC-12V600W1BA

### Operating Mode

#### ■ Parallel Operation

The power supply units (PSUs) can also be used for parallel operation in order to increase the output power. The difference in output voltage between the two units must be kept to within 25mV of each other. This difference must be verified with the same output load connected independently to each unit.

Parameters such as EMI, inrush current, leakage current, PARD, start up time will be different from those on the datasheet, when two units are connected in parallel. The user will need to verify that any differences will still allow the two power supplies connected in parallel will work properly in their product/application.

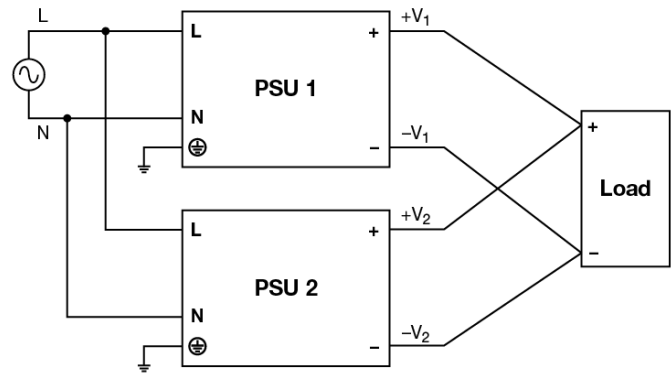

Fig. 4 Parallel Operation Connection Diagram

#### ■ DC Input Operation

##### Step 1.

Use a battery or similar DC source.

##### Step 2.

Connect +pole to L and -pole to N.

##### Step 3.

Connect the PE terminal to an earth wire or to the machine ground.

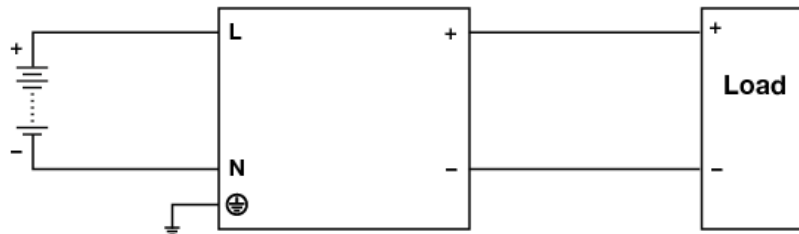

Fig. 5 DC Input Operation Connection Diagram

# PMC Panel Mount Power Supply

## 12V 600W 1 Phase / PMC-12V600W1BA

### ■ 2 of 3 Phase System Input Operation

Delta's PMC can use on 2 of 3 phase system. Please refer to the following step.

#### Step 1.

The input voltage applied from Line to Neutral is below the maximum rated input. The input voltage shall be below 240Vac +10%.

#### Step 2.

The external protector is needed on N (Neutral) input line to secure a safety. N line does not have internal fuse protection. An appropriate fuse or circuit breaker should be connected in series with N input line connection like the following.

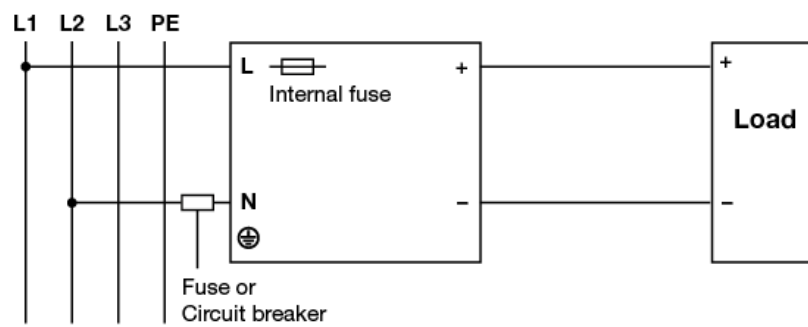

Fig. 6 2 of 3 Phase System Input Operation Connection Diagram

# PMC Panel Mount Power Supply

## 12V 600W 1 Phase / PMC-12V600W1BA

### Others

#### Delta RoHS Compliant



#### Restriction of the usage of hazardous substances

The European directive 2011/65/EU limits the maximum impurity level of homogeneous materials such as lead, mercury, cadmium, chrome, polybrominated flame retardants PBB and PBDE for the use in electrical and electronic equipment. RoHS is the abbreviation for "Restriction of the use of certain hazardous substances in electrical and electronic equipment".

This product conforms to this standard.

#### PFC – Norm EN 61000-3-2

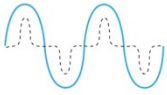

#### Line Current Harmonic content

Typically, the input current waveform is not sinusoidal due to the periodical peak charging of the input capacitor. In industrial environment, complying with EN 61000-3-2 is only necessary under special conditions. Complying to this standard can have some technical drawbacks, such as lower efficiency as well as some commercial aspects such as higher purchasing costs. Frequently, the user does not profit from fulfilling this standard, therefore, it is important to know whether it is mandatory to meet this standard for a specific application.

### Attention

Delta provides all information in the datasheets on an "AS IS" basis and does not offer any kind of warranty through the information for using the product. In the event of any discrepancy between the information in the catalog and datasheets, the datasheets shall prevail (please refer to [www.nrcelectronics.com/delta\\_contact\\_form/](http://www.nrcelectronics.com/delta_contact_form/) for the latest datasheets information). Delta shall have no liability of indemnification for any claim or action arising from any error for the provided information in the datasheets. Customer shall take its responsibility for evaluation of using the product before placing an order with Delta.

Delta reserves the right to make changes to the information described in the datasheets without notice.